

More information:

www.blug.es/eng/productos/



REFERENCE

C2H-2,8

MAXIMUM MATERIAL DENSITY

2,8 T/M³

TYPE

LOW HEIGHT

RELATED PRODUCTS



C2-2,8



CV2-2,8



C2A-2,8

MACHINE TYPE
CLAMSHELL GRAB
WORKING SYSTEM
ELECTRO-HYDRAULIC
MATERIAL TO BE HANDLED

PILED AND BULK MATERIAL UP TO 2,8 t/m³ DENSITY

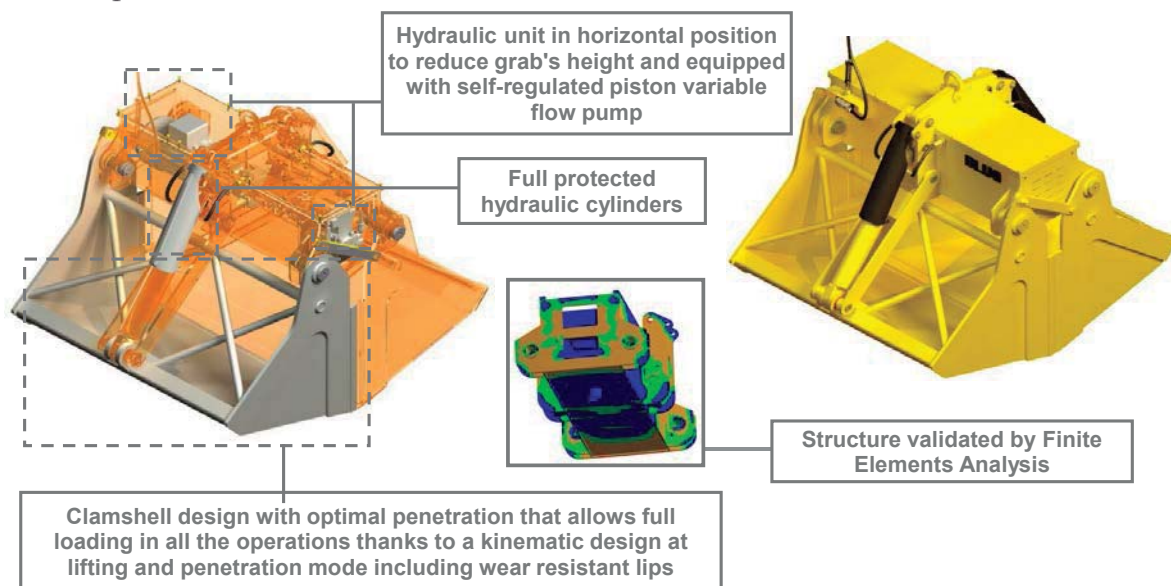

Equipment needed

- Hook(s) or lifting chain(s).
- Electric connection for hydraulic unit.

Technical information

- Robust structure in S355 J2G3 rolled steel.
- Oil tank tightly enclosed and protected from environment impurities.
- Reduced height, multi-stable, can work at any angle (± 60°).
- Design & fabrication according to standard FEM 1001/98 section I.
- CE conformity.

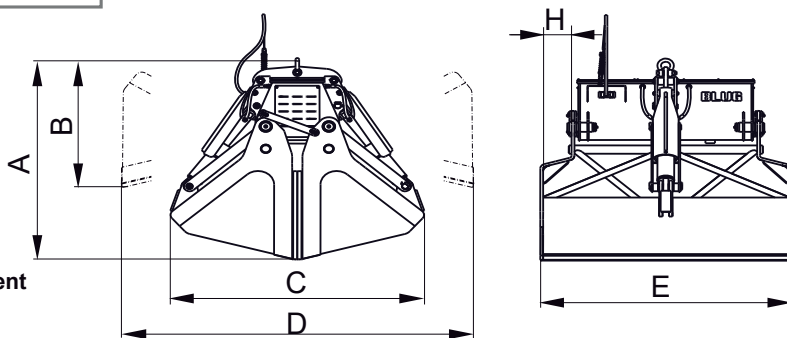

Reference	Capacity m ³	Engine 40% ED kW	Intensity 400 V A	Working pressure bar	Closing time s	Opening time s	Crane SWL t	Weight kg	Dimensions mm					
									A	B	C	D	E	H
C2H-800-2,8	0,8	7,3	14,5	150	10	5	4	1570	1645	1145	1800	2310	1465	0
C2H-1000-2,8	1	10	20	190	10	5	6	1635	1645	1145	1800	2310	1655	95
C2H-1600-2,8	1,6	14,5	28	180	14	7	8	2350	1770	1245	2300	2645	1800	0
C2H-2000-2,8	2	14,5	28	160	13	7	10	2935	1865	1305	2445	2805	1905	0
C2H-2500-2,8	2,5	20,5	39	220	13	7	12	3315	1965	1340	2445	2975	1895	0
C2H-3000-2,8	3	25,5	48,5	180	13	7	14	3820	2120	1420	2600	3240	1990	0
C2H-3500-2,8	3,5	25,5	48,5	210	13	7	16	3920	2120	1420	2600	3240	2250	130

SUBJECT TO CHANGE WITHOUT NOTICE.

You can request any model's offer visiting our web site www.blug.es or sending an email to comercial@blug.es